



# GP

**Open  
refrigerant pumps**  
*Installation and  
operating instructions*

- GP 41**
- GP 42**
- GP 51**
- GP 51A**
- GP 52**
- GP 82**



## 4. TECHNICAL DATA

### 4.1 GENERAL INFORMATION

DESCRIPTION	GP 41	GP 42	GP 51	GP 51a	GP 52	GP 82
Volume refrigerant side [ltr.]	1,75	1,85	4,10	4,10	5,25	7,72
Reservoir oil content [ltr.]	1,70	1,70	2,00	2,00	2,00	2,00
Flange connection [DN]	40,00	40,00	50,00	50,00	50,00	50/80
Weight [kg] for						
Model 1	41,00	45,00	63,00	63,00	73,00	91,00
Model 2	48,00	52,00	75,00	75,00	92,00	110,00
Model 4	dependent	dependent	dependent	dependent	dependent	dependent

### 4.2 MOTOR DATA

#### 4.2.1 Motor data for 50 Hz - 1.500 RPM

	Density [kg/dm <sup>3</sup> ]	Motor size	Power [kW]	Voltage [V]		Weight [kg]	Remark	
				Δ	Y			
GP 41	< 0,7 (NH3)	80	0,55	220 - 240	380 - 420	10	Standard	
	< 1,4		0,75			12		
	< 1,6	90S	1,1			14		
	< 1,8							
GP 42	< 0,7 (NH3)	90S	1,1	220 - 240	380 - 420	14	Standard	
	< 1,4	90L	1,5			17		
	< 1,6		2,2			22	Motor adapter ring necessary	
	< 1,8	100L						
GP 51	< 0,7 (NH3)	100L	3	220 - 240	380 - 420	28	Standard	
	< 1,4	112M	4			40		
	< 1,6	132S	5,5			660 - 725	66	Motor adapter ring necessary
	< 1,8							
GP 51a	< 0,7 (NH3)	100L	2,2	220 - 240	380 - 420	17	Standard	
	< 1,4	112M	4	220 - 240	380 - 420	40		
	< 1,6			380 - 420	660 - 725			
	< 1,8							
GP 52	< 0,7 (NH3)	132S	5,5	220 - 240	380 - 420	66	Standard	
GP 82	< 0,7 (NH3)	132M	7,5	380 - 420	660 - 725	64	Standard	

#### 4.5.6 Dimensions in mm Strainer KS + ERA and 2x EA

	GP41/42	GP51/52	GP82
h1	123	123	123
f1	328	328	328
h2	123	123	193
f2	358	358	484
h3	107	135	131
f3	234	267	324
l1	372	405	498
h4			123
f4			358

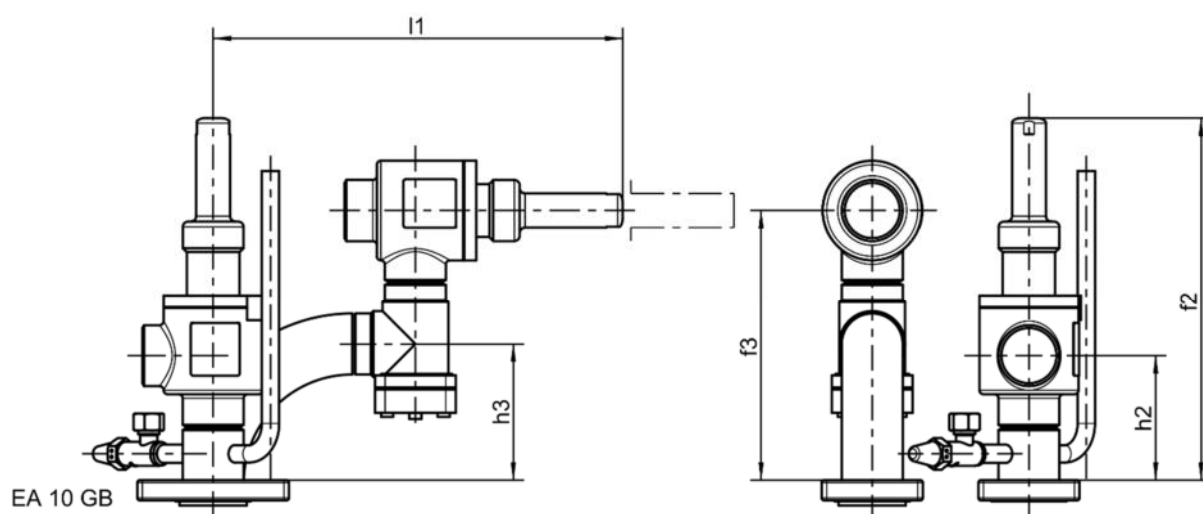

Modell ERA + KS

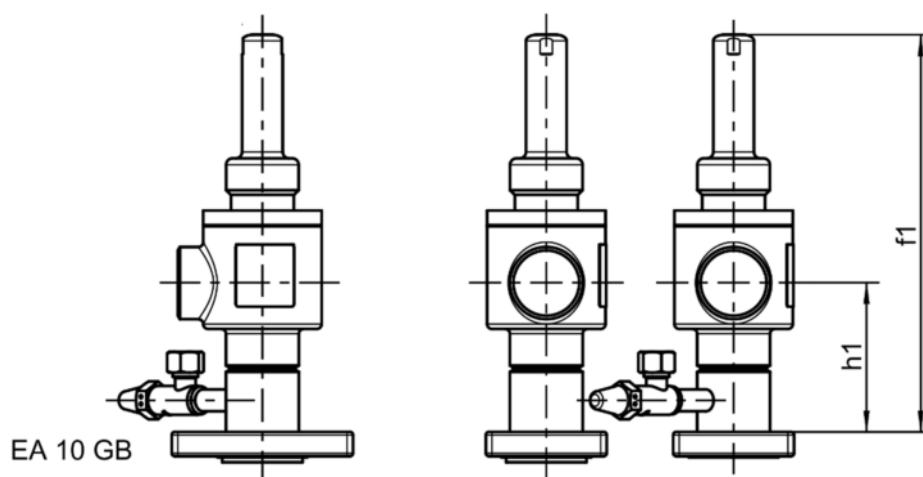

Modell 2 x EA

## 4.9 DESCRIPTION OF OPERATION

From the surge drum refrigerant liquid flows into the suction chamber of the pump. A conical filter is positioned in the suction connection. A special design of the suction chamber reduces the inlet friction. The fluid pressure is increased by passing through one or two stage impellers and intermediate piece(s).

Due to the lateral channels in the intermediate pieces the pump can deliver a gas/liquid mixture without surging or reversing the flow.

The special double shaft seal with associated oil reservoir in the between ensures that no refrigerant will escape outside the system.

During standstill any gas that evaporates must be able to leave the pump and vent to the surge drum. If the pump can be isolated on the delivery side or if a return valve is mounted, a purge line with a diameter of 10 mm (0.4") must be installed between delivery flange and stop valve and connected to the wet suction return line.

The stop/return valve ERA is provided with a purge connection pipe DN 10 and a hand regulating valve EE6, supplied loose. The EE6 should be fitted so that any gas may be purged to the surge drum. The valve should be left ½ - ¼-turn open depending on the differential pressure (see also fig. 6).

## 4.10 PERFORMANCE CHARACTERISTIC TABLE

1450 1/min (RPM)

LIQUID HEAD [m]	PRESSURE DIFFERENCE [bar]				VOLUME FLOW [m³/h]					
	NH <sub>3</sub>		R 22		GP 41	GP 42	GP 51A	GP 51	GP 52	GP 82
	EVAPORATING TEMPERATURE t <sub>0</sub>									
	+40°C	-40°C	+40°C	-40°C						
2	0,11	0,14	0,22	0,28	3,4	3,6	10,2	16,8	16,8	24
4	0,23	0,27	0,44	0,55	3,2	3,4	10	16,5	16,5	23,5
6	0,34	0,41	0,67	0,83	2,9	3,3	9,7	16,3	16,3	23
8	0,45	0,54	0,89	1,13	2,7	3,1	9,4	16,1	16,2	22,4
10	0,57	0,68	1,11	1,38	2,6	3	9	15,7	16,1	21,8
15	0,85	1,02	1,67	2,08	2,2	2,6	8,3	14,2	16	20,3
20	1,14	1,35	2,22	2,77	1,8	2,4	7,4	12,3	15,8	19
25	1,42	1,69	2,78	3,46	1,4	2,1	6,3	9,8	15,1	17,8
30	1,7	2,03	3,33	4,15	-	1,9	5,5	7	14,2	16,6
35	1,99	2,37	3,89	4,84	-	1,6	4,5	3,6	13,5	15,5
40	2,27	2,71	4,45	5,54	-	1,3	-	0	12,5	14,3
45	2,56	3,05	5	6,23	-	1,1	-	-	11,1	13
50	2,84	3,38	5,56	6,92	-	0,8	-	-	10,4	11,6
55	3,12	3,72	6,11	7,61	-	-	-	-	9,3	10
60	3,41	4,06	6,67	8,31	-	-	-	-	8	8,4
65	3,69	4,4	7,22	9	-	-	-	-	6,5	-
70	3,98	4,74	7,78	9,69	-	-	-	-	5	-

1 m = 3.281 ft | 1 bar = 14.504 PSI | 1 m³/h = 4.403 gal/min

## RECIRCULATION RATES AND PUMP CAPACITY

Refrigerant	Recirculation factor			Recirculation flow in m <sup>3</sup> /hr per 100 kW*		
	CO <sub>2</sub>	NH <sub>3</sub>	R22	CO <sub>2</sub>	NH <sub>3</sub>	R22
Air Cooler	1,2 – 2,0	3 - 4	2 - 3	1,4 – 2,4	1,3 – 1,8	2,8 – 4,3
Plate Freezer	5 - 10	7 - 10	5 - 10	6 - 12	3 – 4,5	6,5 - 13
Liquid Chiller	1,2 – 1,5	1,2 – 1,5	1,2 – 1,5	1,4 – 1,6	0,6	1,7

\*) including re-circulation rate

### 5.4 ADAPTATION TO PLANT REQUIREMENTS

Fig. 5 shows different plant operating conditions. The delivery head  $H$  is shown in relation to the required plant capacity  $Q$ .

Performance curve characteristics of the refrigerant pump are shown in fig 5A. The different points  $W$  mark the varying plant conditions that may occur during operation.

If the required liquid flow does not correspond with the available pump capacity then the liquid flow to the system can be adjusted as follows:

#### pump capacity too large:



- switch off a pump
- open a liquid bypass valve, fig. 5B
- speed control of the pump, fig 5C

#### pump capacity too small:

- switch on an extra pump, fig 5D
- install a larger pump

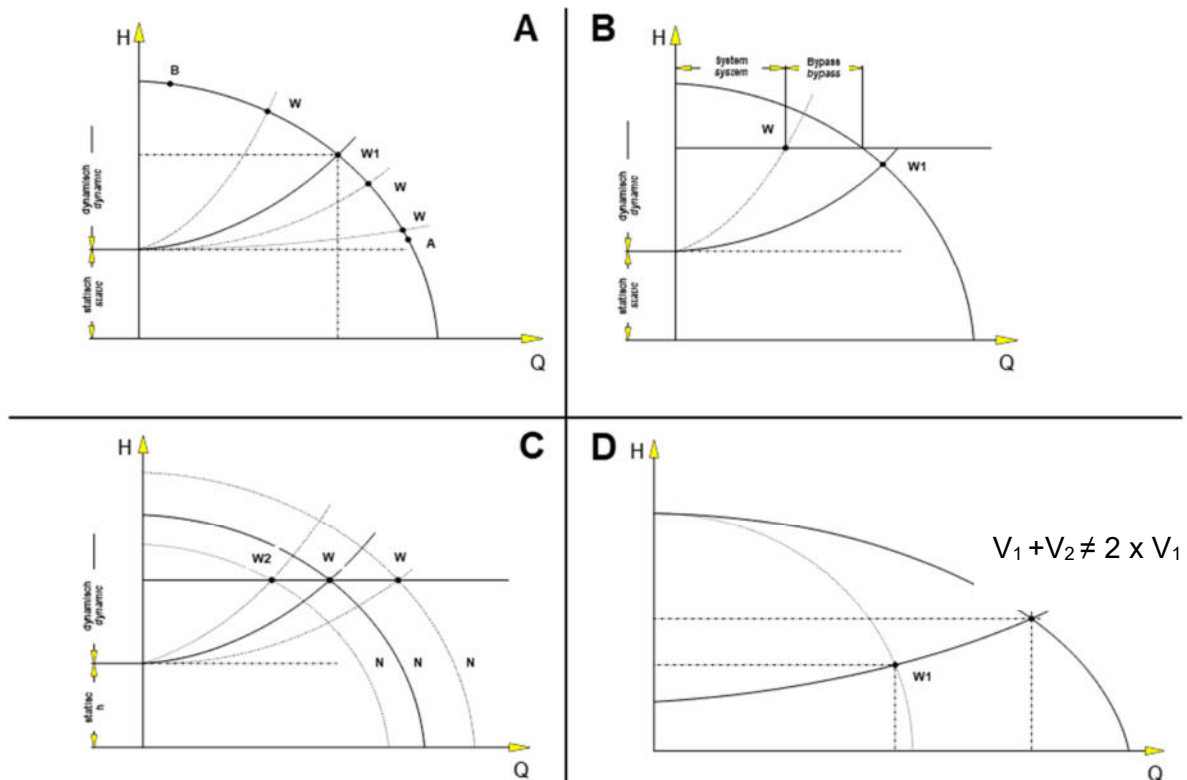

Fig. 5, A-D

### 6.5.1 Safeguarding against too high pressure



Operating refrigerant pumps against too high pressure (e.g. against partially or fully closed throttled condition) is not allowed and will damage the refrigerant pump!

A **by-pass valve** (adjustable) has proven good practice to safeguard the pump against too high pressure.

To set the by-pass valve select the pressure difference across the pump according table 1 for the following de-livery head. (take into account the pressure losses in the pipework to the by-pass valve)

	960 RPM	1150 RPM	1450 RPM	1740 RPM
GP 41	11 m	16 m	25 m	36 m
GP 42	20 m	30 m	48 m	70 m
GP 51	13 m	19 m	31 m	47 m
GP 51a	16 m	23 m	37 m	50 m
GP 52	26 m	40 m	65 m	-
GP 82	-	-	55 m	85 m



A diameter of DN20 has been proven for the by-pass valve.

### 6.5.2 Dry-run protection

If a **minimum level cut out switch** is mounted on the separator, it shall be used to switch the pump off in case of a lack of refrigerant (dry run protection).

### 6.5.3 Pressure differential switch

A pressure differential switch - with time delay during start up - shall be used when there is insufficient discharge pressure.

The delay should be set at approx. 30 s, which means if the pump was not able to build up pressure (e.g. 0,3 – 0,5 bar) within 30 s, the pump will be stopped

This procedure can be repeated a maximum of four times. Then a malfunction message should be submitted and the pump switched off. After that a restart should only be made after investigation of the cause of failure and acknowledging the fault indicator.

The pressure differential switch does not protect the pump against too high pressure running (dead heading)!

### 6.5.4 Flow switch

A **flow switch** must be installed, when a bypass valve is not fitted in the refrigerant circuit. It is known when the bypass valve is not fitted, the pump is capable of producing a differential pressure without volume flow and has not been stopped by the differential pressure switch. The flow switch control in the pump discharge shall stop the flow as the flow drops below 0,2 m/s.

See also WITT information sheet W 4652-0.01





**TH.WITT**  
**Kältemaschinenfabrik**  
**GmbH**

Lukasstraße 32, 52070 Aachen, Germany  
Tel. +49 241 18208-0  
sales@th-witt.com

[www.th-witt.com](http://www.th-witt.com)